

Data Sheet EPW 125

Press head EPW 125 Specifications

- In line or parallel Version
- Working versions position: Vertical, Horizontal, Sub-vertical, Universal Parallel
- Threaded bolts or screws "TX" version
- Work force at 6 bar : 73,9 kN
- Approach force at 6 bar : 10,3 kN
- Total force at 6 bar : 84,2 kN
- Return force at 6 bar : 9,5 kN
- Standard total strokes : 45-75-115-165 mm
- Standard working strokes : 5-10-15 mm
- Approaching recommended speed : 0,3 m/sec
- Anodized aluminium
- Standard magnetic unit
- Connection with high pressure chamber
- Adjustable return stroke cushioning
- Rod connection model "AF" or "AS" or "AT"
- Possibility to manage the working cycle in an independent way from the approaching phase
- Possibility to manage the unit with low pressure
- Without external tank
- 3D or 2D drawings on request
- Usage instructions in pdf format
- Incorporation statement
- Unit testing certificate

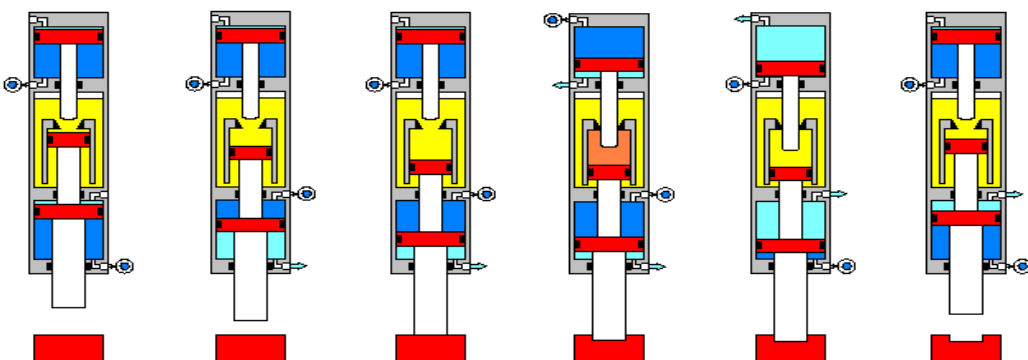
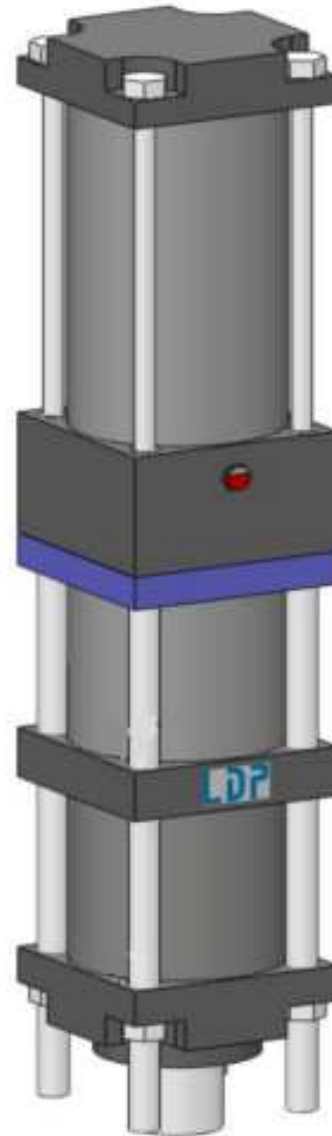

EPW125

Tot.Stroke 45 mm	L mm	Tot.Stroke 75 mm	L mm	Tot.Stroke 115 mm	L mm	Tot.Stroke 165 mm	L mm
40-05	674	70-05	734	110-05	814	160-05	914
35-10	704	65-10	764	105-10	844	155-10	944
30-15	734	60-15	794	100-15	874	150-15	974

Connections chart

- A= Force cylinder forward
- B= Force cylinder return
- C= Approach cylinder forward
- D= Approach cylinder return
- P= Pressure tap
- R= Oil topping up
- S= Oil drain

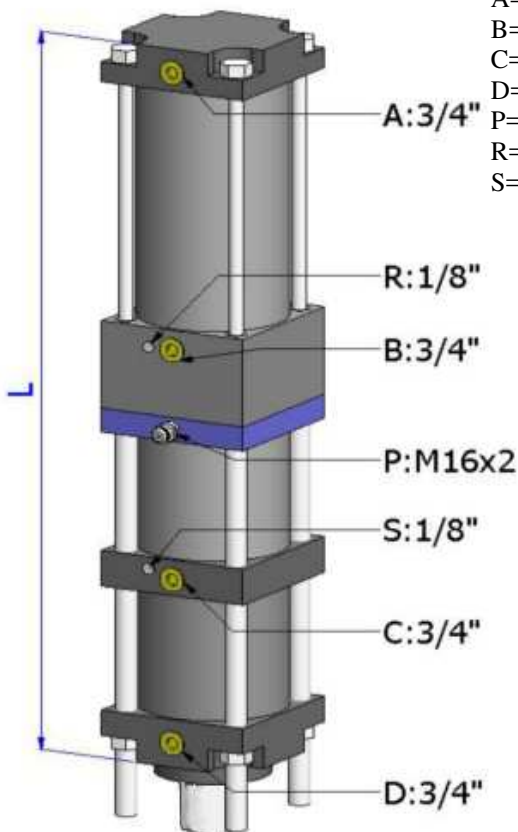

Threaded bolts unit version

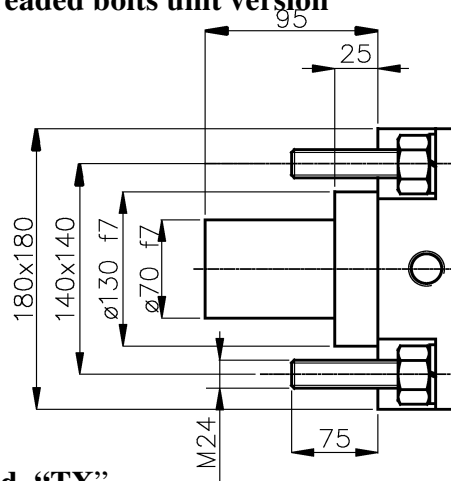

Screw unit version mod. "TX"

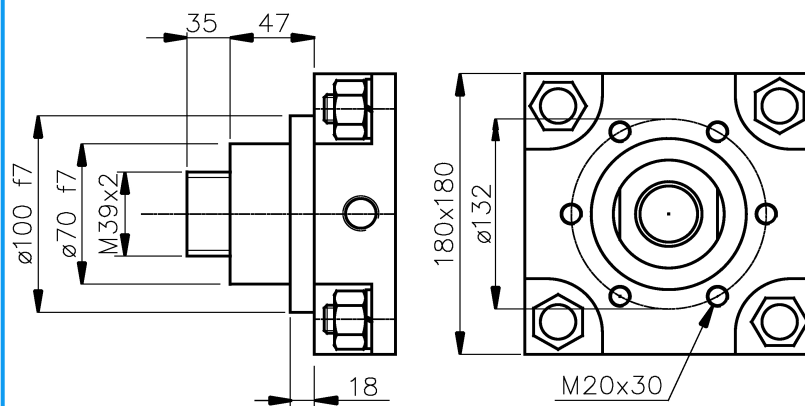

Rod Connection

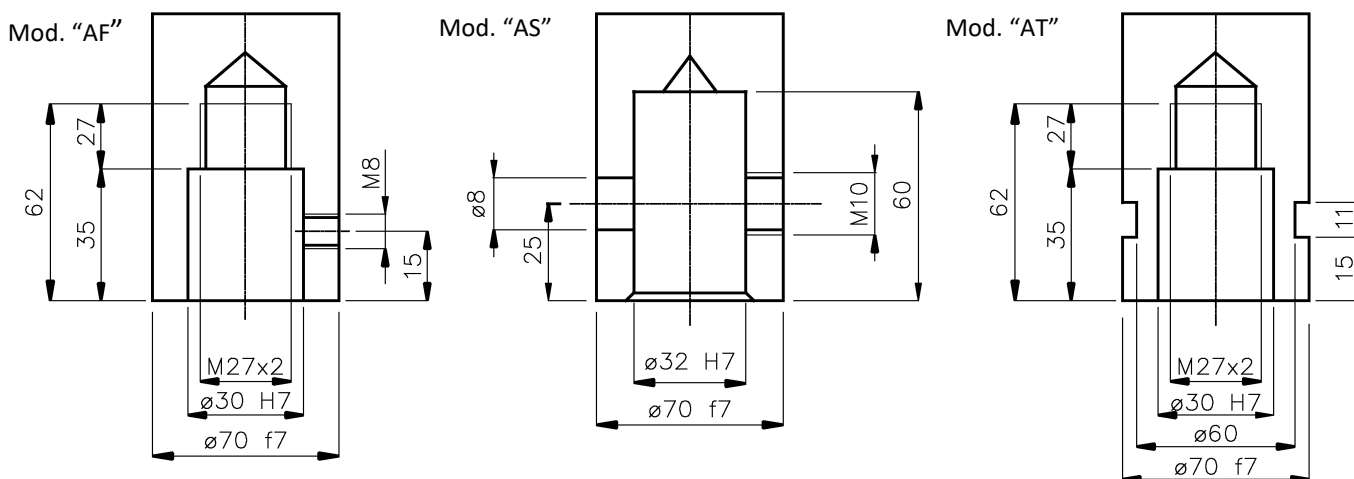

PRODUCTION PROGRAMME:
- Pressure booster, Air-Oil cylinders

- E-Type, CS-Type, KS-Type and special Press heads - Clenching systems
- Pneumatic and Hydropneumatic units with swan neck as well as pillars type

LDP ITALIA s.r.l. Società a socio unico Cap. Soc. € 100.000,00 – P.IVA IT06891250158 – R.E.A. Milano 1126616
 ◇ Sede Legale – Head Office Via G. Puccini 13 – 20085 Locate di Triulzi – MILANO www.ldpitalia.com - E-mail info@ldpitalia.com
 ◇ Unità Produttiva – Productive Unit Via del Lavoro 8 – 24050 Bariano – BERGAMO - Phone +39 0363 95096